



WOOMBER



991223227 – 956569570 -935408473 – 013886010
 AV. POLONIA 1509 LIMA-SJL

CYLINDER HEAD ASSY/CYLINDER ASSEMBLY

NO.	WOOMBER W10	QT
1	NUT M8	4
2	WASHER 8.5×2×18	4
3	BOLT M6×35	4
4	COVER, VALVE CHAMBER	2
5	O-RING 35×3	2
6	SPARK PLUG	1
7	PIN 8×14×6.3	2
8	RECTANGLE RING	1
9	CYLINDER HEAD ASSY	1
10	O-RING 33.5×3	1
11	BOLT	2
12	INLET PIPE	1
13	NUT M6	2
14	BOLT M6×20	2
15	NUT M8	2
16	CARBURETOR	1
17	BOLT M8×38	2
18	BOLT M6×119	1
19	WASHER 6.2×2×13	1
20	PIN 10×20	2
21	O-RING 75×2.65	1
22	GASKET, L, CYLINDER HEAD COVER	1
23	LEFT COVER, CYLINDER HEAD	1
24	BOLT M6×20	2
25	GASKET ASSY, CYLINDER HEAD	1
26	CYLINDER BLOCK ASSEMBLY	1
27	GASKET, CYLINDER BLOCK	1
28	ROCKER SHAFT BAFFLE	23

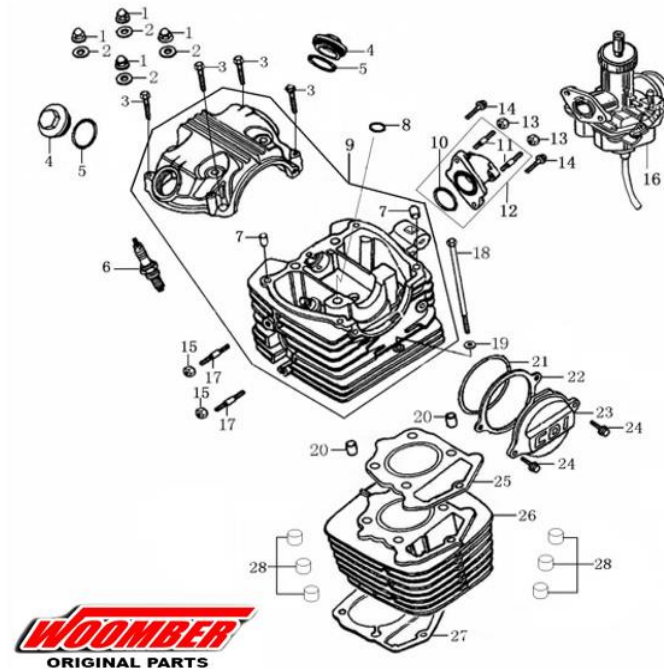

VALVE MECHANISM

NO.	WOOMBER W10	QT
1	NUT, VALVE CLEARANCE	2
2	SCREW, VALVE CLEARANCE	2
3	ROCKER ARM ASSEMBLY, VALVE	2
4	VALVE LOCKER	4
5	SPRING SEAT	2
6	INNER SPRING, ASSY	2
7	SEAL, VALVE STEM	2
8	SPRING SEAT	2
9	OUTER VALVE SPRING RETAINER	2
10	EXHAUST VALVE	1
11	INTAKE VALVE	1
12	GUIDE PLATE CHAIN	1
13	TIMING DRIVEN SPROCKET	1
14	BOLT M6×12	2
15	SPROKET CHAIN	1
16	TENSION PLATE ASSY	1
17	WASHER 8.5×1.5×14	1
18	BOLT	1
19	GASKET, TENSIONER	1
20	LIFTER ASSY	1
21	SCREW M6×16	2
22	O-RING 9×1.8	1
23	BOLT M6×6	1
24	ROCKER SHAFT	1
25	GAMP SHAFT COMP	1
26	POSITION PLATE, ROCKER SHAFT	1
27	SCREW M6×16	1
28	ASSEMBLY, CHAIN PROTECT PLATE	1
29	BOLT M6×16	1
30	ROCKER SHAFT	1

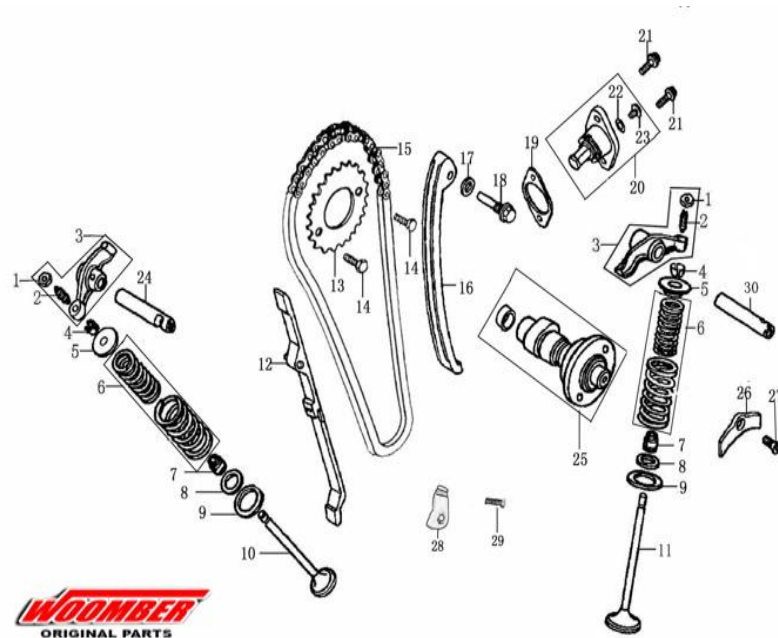

CRANKCASE COVER		
NO.	WOOMBER W10	QT
1	BOLT M6×25	1
2	BOLT M6×35	1
3	BOLT M6×40	9
4	BOLT M6×50	1
5	OIL LELVE SIGHT WINDOW	1
6	OIL SEAL 16×28×7	1
7	CONTROLLING ARM ASSEMBLY, CLUTCH	1
8	OIL SEAL 12×22×5	1
9	CLUTCH CONTROLLING ARM SPRING	1
10	CLUTCH LEVER PIN	1
11	OIL RULER ASSY	1
12	O-RING 18×3	1
13	COVER COMP. RIGHT CRANKCASE	1
14	PIN 8×14×6.3	2
15	GASKET, R. CRANKCASE COVER	1
16	BOLT M6×25	3
17	SCREW M6×12	4
18	BOLT M6×35	1
19	BOLT M6×20	3
20	BOLT M6×28	2
21	BOLT M6×55	2
22	BOLT M6×40	1
23	BOLT M6×60	1
24	BEARING	1
25	FRONT PART, L. CRANKCASE COVER	1
26	PIN 8×14×6.3	2
27	GASKET, L. CRANKCASE COVER	1
28	CAP, SMALL VIEW HOLE	1
29	O-RING 13.2×2.65	1
30	O-RING 27.4×2.65	1
31	BACK PART, L. CRANKCASE COVER	1
32	DECORATE COVER ,L. CRANKCASE COVER	1
33	O-RING 63×2.65	1
34	COVER, REDUCTION GEAR	1
35		
36		

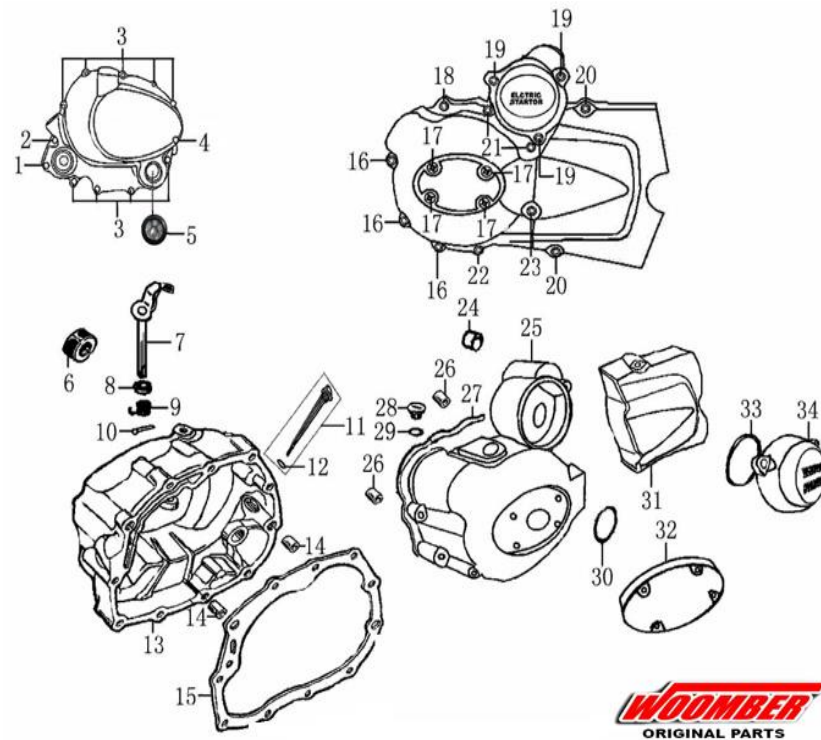

OIL PUMP/OIL FILTER		
NO.	WOOMBER W10	QT
1	OIL FILTER, COMP	1
2	OIL PIPE	1
3	SCREW M5×12	3
4	SPRING, OIL PIPE	1
5	OIL FILTER COVER	1
6	OPEN PIN	1
7	GASKET, OIL FILTER	1
8	NUT	1
9	DISH WASHER, CLUTCH	1
10	ROTOR ASS. OF OIL FILTER	1
11	PRIMARY DRIVE GEAR	1
12	O-RING 9.4×2.4	2
13	SCREW M4×10	2
14	OIL PUMP COVER	1
15	INNER ROTOR, OIL PUMP	1
16	OUTER ROTOR, OIL PUMP	1
17	OIL PUMP BODY	1
18	GEAR, OIL PUMP	1
19	SHAFT, OIL PUMP	1
20	OIL PUMP GEAR COVER	1
21	BOLT M5×20	2
22	SCREW M6×30	2
23	OIL PUMP ASSY	1

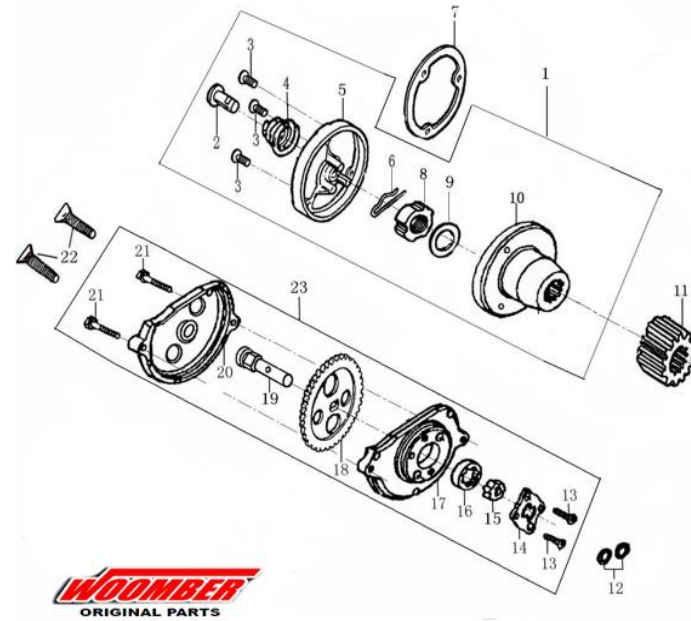

CRANKCASE		
NO.	WOOMBER W10	QT
1	BOLT M6×60	1
2	HOLDER, CLIUTCH CABLE	1
3	CYLINDER STUD BOLT A	1
4	CYLINDER STUD BOLT A	1
5	BOLT M6×32	2
6	CLAMP	2
7	BREATH TUBE	1
8	OIL AIR FILTER	1
9	BREATH TUBE	1
10	RIGHT CRANKCASE BLOCK	1
11	GASKET, CRANKCASE	1
12	LEFT CRANKCASE BLOCK	1
13	STRAINER, OIL FILTER	1
14	SPRING, OIL FILTER STRAINER	1
15	O-RING 35×3	1
16	COVER, VALVE CHAMBER	1
17	OIL-SEAL 14×28×7	1
18	GEARSHIFT SWITCH PLATE	1
19	NUT	1
20	GEARSHIFT SWITCH LAMP	1
21	POSITION PLATE	1
22	BOLT M6×12	1
23	BOLT M6×50	10
24	BEARING	1
25	PIN 10×14	4
26	CYLINDER STUD BOLT B	2
27	OIL SEAL 20×34×7	1
28	BEARING (6204)	1
29	BEARING (TM6202Z)	1
30	BEARING (6006)	1
31	BEARING (NK152312)	1
32	CLAMP	1

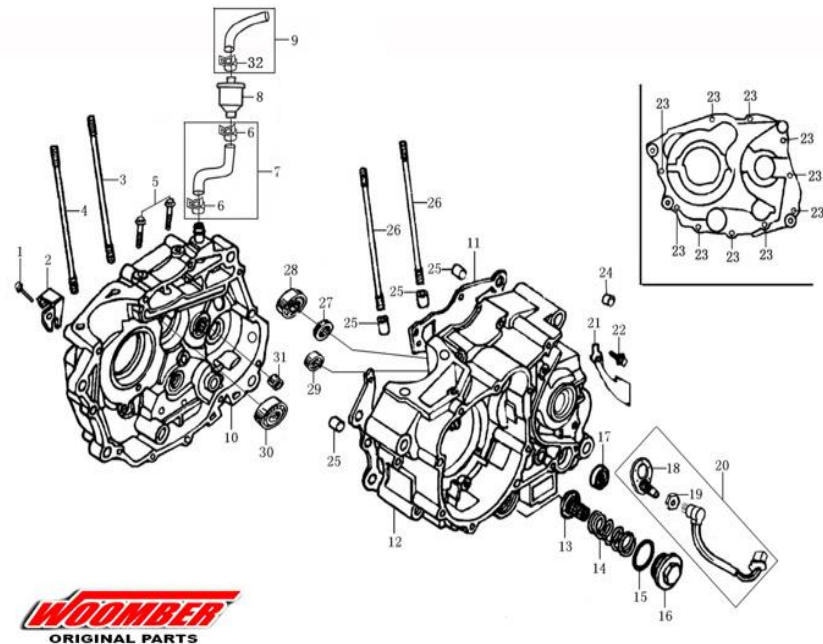

CRANKSHAFT CONNECTING-ROD ASSY/PISTON

NO.	WOOMBER W10	QT
1	PISTON RING 1	1
2	PISTON RING 2	1
3	OIL RING ASSY	1
4	PISTON RING COMP	1
5	CHECK RING, PISTON PIN	2
6	PIN PISTON	1
7	PISTON	1
8	BEARING (63/28/P5)	2
9	CONNECTING ROD COMP 3	1
10	SEMICIRCULAR KEY	1
11	HUB DUMP CHAIN SPROCKET	1
12	CRANKSHAFT CONNECTING-ROD ASSY	1
13		
14		
15		
16		
17		
18		
19		
20		
21		
22		
23		
24		

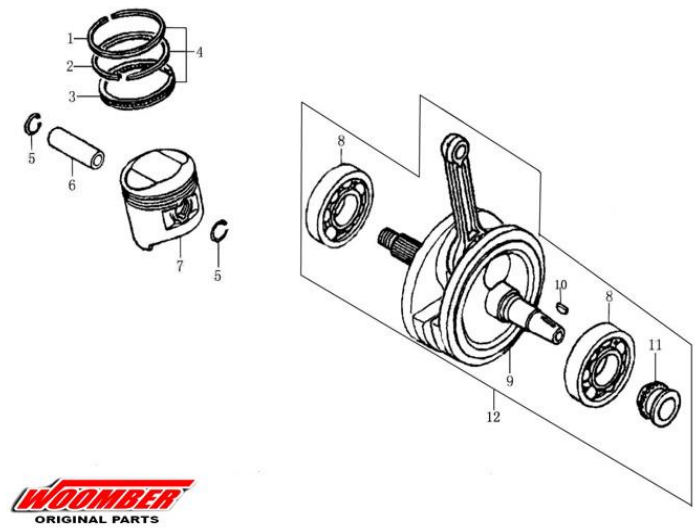

TRANSMISSION MAIN, COUNTER SHAFT

NO.	WOOMBER W10	QT
1	WASHER 15.2×1×25	1
2	GEAR M-2	1
3	GEAR M-5	1
4	WASHER	3
5	CIRCLI ϕ 18.5×1.2× ϕ 22.1	3
6	GEAR M-4	1
7	GEAR M-3	1
8	TRANSMISSION MAIN SHAFT	1
9	WASHER 20.2×0.5×27	1
10	FINAL SHAFT	1
11	WASHER 15.2×1×30	1
12	GEAR	1
13	GEAR BUSH	1
14	WASHER 16.5×0.5×24	2
15	GEAR C-1	1
16	GEAR BUSH	1
17	GEAR C-3	1
18	GEAR C-4	1
19	TRANSMISSION COUNTER SHAFT	1
20	GEAR C-5	1
21	GEAR C-2	1
22	WASHER 20×1×27	1
23	DRIVE SPROCKET	1
24	FIXING PLATE, DRIVE SPROCKET	1
25	BOLT M6×10	2
26	MAIN SHAFT, TRANSMISSION	1
27	COUTERSHAFT TRANSMISSION	1
28	TRANSMISSION MAIN, COUNTER SHAFT	1
29		

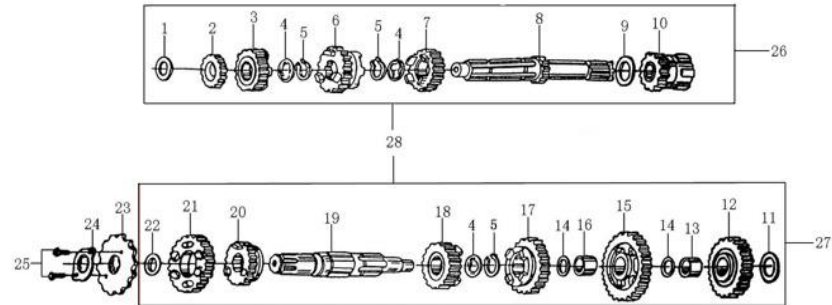

KICK STARTING SHAFT ASSEMBLY		
NO.	WOOMBER W10	QT
1	KICK STARTING SHAFT ASSEMBLY	1
2	O-RING 11.8×2.65	1
3	BOLT M12×25	1
4	WASHER 12.1×1×18	1
5	CIRCLIP 16	1
6	GUIDE PLATE	1
7	SPRING, KICK STARTING RATCHET WHEEL	1
8	STARTING RATCHET	1
9	CIRCLI $\phi 18.5 \times 1.2 \times \phi 22.4$	1
10	WASHER 20×0.5×27	1
11	GEAR, KICK STARTER	1
12	PIVOT, KICK STARTING SHAFT	1
13	SEAT, SPRING, KICK STARTING SHAFT	1
14	RETURN SPRING, KICK STARTING SHAFT	1
15	SLEEVE	1
16	START-UP BAR COMP	1

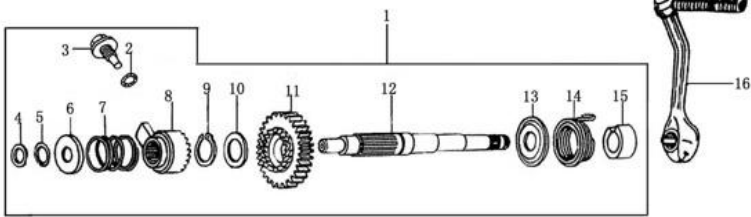

GEARSHIFT MECHANISM		
NO.	WOOMBER W10	QT
1	CIRCLIP 12	1
2	SPRING, GEARSHIFT PLATE	1
3	GEARSHIFT PLATE	1
4	GEARSHIFT SHAFT COMP	1
5	RETURN SPRING	1
6	WASHER 14×0.5×20	2
7	CIRCLIP 14	1
8	GEARSHIFT LEVER COMP	1
9	BOLT M6×20	1
10	GEARSHIFT SHAFT	1
11	SHAFT, GEARSHIFT FORK	1
12	RIGHT FORK, COUNTERSHAFT	1
13	CENTER FORK, MAINSHAFT	1
14	LEFT FORK, COUNTERSHAFT	1
15	BOLT	1
16	WASHER φ6	1
17	STOPPING PLATE	1
18	PIN 4×10	1
19	GEARSHIFT DRUM	1
20	SPRING, LOCATING PLATE	1
21	LOCATING PLATE ASSY	1
22	BOLT FIXING PLATE	1

